



## Main Features:-

- ◆ 2pc Design Stainless Ball Valve
- ◆ Economy Ball Valve
- ◆ ANSI 150 Flanged
- ◆ PTFE seats and Seals
- ◆ -20C to + 180C Temperature Rating CL 150

\*Temperature and pressure determined by valve body, seat etc.

## Suitable Applications & Approvals:



## SERIES: 10118

MANUFACTURER: **AVOL**  
INDUSTRIAL VALVES

SIZE	CODE	D	L	B	P	X	S	S1	H	W	KG
1/2"	1043-04	15	108	11.2	2	8.6	19.8	6.3	94	138	1.6
3/4"	1043-05	20	117	12.7	2	8.6	21	7.5	97	138	1.9
1"	1043-06	25	127	14.3	2	10	24.3	9.1	115	173	3.1
1 1/2"	1043-08	38	165	17.5	3	12	36	17.5	141	195	5.8
2"	1043-09	50	178	19.1	3	12	37.2	18.7	149	195	8.0
3"	1043-11	80	203	23.9	3	16	47	26.1	172	328	17.9
4"	1043-12	100	229	23.9	3	16	44.3	23.4	187	328	27.7
6"	1043-14	150	394	25.4	3	27	47	-	215	525	65.3

VALVE DIMENSIONS

## DIMENSIONAL DRAWING OF VALVE

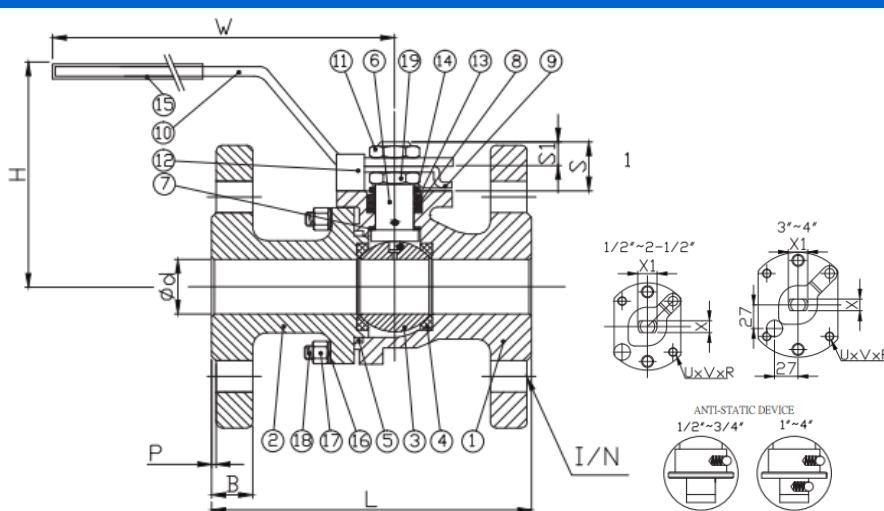

## MATERIALS OF CONSTRUCTION

BODY	CF8M SS
BALL	CF8M
BODY SEAT	PTFE
STEM	316 SS
ORINGS	PTFE
PRESSURE	CL 150
TEMP	-20 to +180C



T +44 (0)1386 552369

E sales@allvalves.co.uk

W www.allvalves.co.uk

F +44 (0)1386 554227